

Differential Pressure Gauges Magnetic-Piston Sensing Element with Diaphragm Type 700.05

WIKA Datasheet 700.05

Applications

- For use in measurement applications requiring high differential/static process pressures.
- Suitable for applications with particulate matter present in liquid/gas media or when separation of the media is required.

Product Features

- Magnetic piston sensing element
- Rugged thermoplastic case
- Buna-N separating diaphragm
- 3000 psig (200 barg) maximum working pressure
- Differential pressure ranges up to 100 psid (7 bard)



Differential Pressure Gauge Model 700.05 2½" & 4½"

Specifications

Pressure connections

Standard:

¼" NPT female, back connection

Optional:

½" NPT female, back connection, with adapters

¼" NPT female, top mount and bottom mount

½" NPT female, top mount and bottom, with adapters

Description

Nominal Sizes

2½" & 4½" (63 & 115 mm)

Accuracy (on increasing pressure)

± 2% of span for ranges 0/15 psid (1 bard) and above

± 5% of span for ranges below 0/15 psid (1 bard)

Scale Ranges

0/50" H₂O through 0/100 psid

(0/125 mbard through 0/7 bard)

Maximum Safe Working Pressure

3000 psig (200 barg)

Operating Temperature

Ambient: -40 °F to 212 °F (-40 °C to +100 °C)

Media: -40 °F to 212 °F (-40 °C to +100 °C)

Weather protection

NEMA 4X (IP 66)

Sensing Element Internal Wetted Parts

Ceramic magnet and 316 SS

Sensor Block

Black anodized aluminum - standard

316L SS- optional

Elastomers (O-rings & diaphragm)

Buna-N - standard

Viton - optional

Case & Bezel

Fiberglass reinforced thermoplastic

Dial

White aluminum with black lettering

Pointer
Black aluminum

Silicone - 1000 CST (changes to Model 703.05)
(No other case fills approved)

Window
Acrylic - standard
Laminated safety glass - optional

Order Options (min. order may apply)
 ■ Red drag pointer - 2 1/2" (4 1/2" - inquire).
 ■ Special connections
 ■ Wall or pipe mounting kit
 ■ Other pressure scales

Dial Case filling
Glycerine - (changes to Model 703.05)

Optional Wall/Pipe Mount Bracket P/N 50006185

Wall Mounting Configuration¹

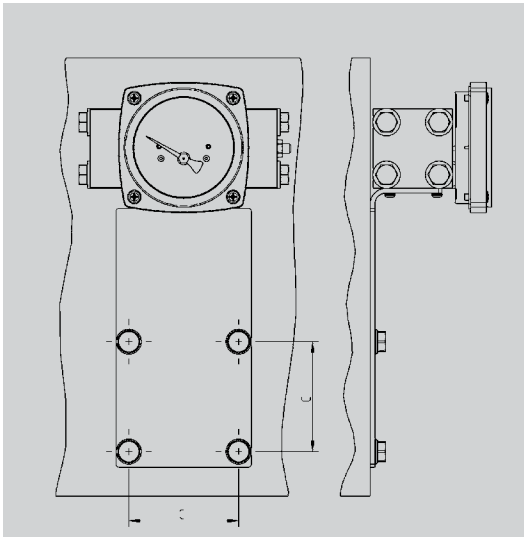

Pipe Mounting Configuration

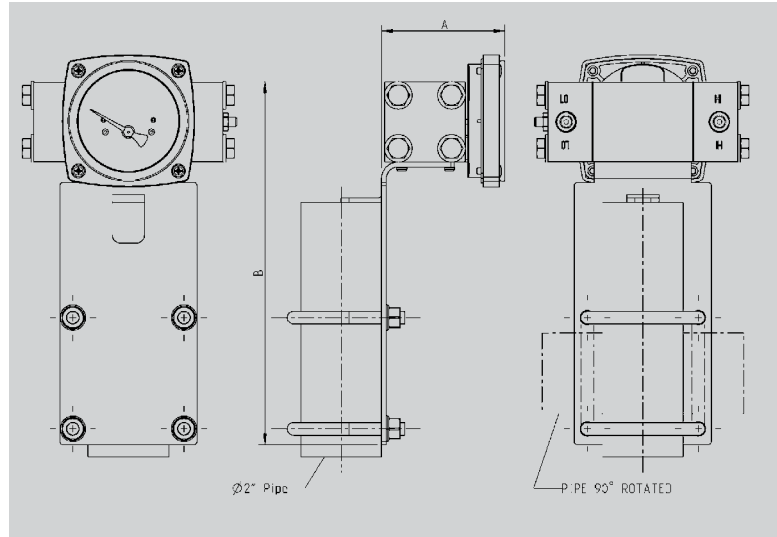

Wall Mount/Pipe Mount Dimensions

Size		A	B	C
2 1/2"	mm	77.7	228.6	70
	in	3.06	9.0	2.76

Standard back connection shown

Notes:

1) Order optional top or bottom connections if standard back connections interfere with wall, or order standoff blocks to space from wall as application requires.

Wall and Pipe Mounting:

The 700.05 has a different sensor housing than the 700.04 model and involves a separating diaphragm. The 700.05 has the ability to have its sensor housing end caps configured in a top connection, bottom connection, back connection, or any combination of those configurations. With the end caps being able to be oriented independently of each other, the customer is provided with a high degree of flexibility for their application. All connection configurations must be done at the factory, as they are not field modification items.

2 1/2" Wall mount

Rear connection configuration will experience a problem for wall mounting unless the bracket & gauge assembly is held off of the wall in some fashion. A 1/2 inch aluminum standoff block is now available to alleviate this problem. Customers can add the number of blocks required to adjust the installation to their particular application. The optional top and bottom connection configurations will not experience this problem and will not require the standoff blocks.

2 1/2" Pipe mount

Unlike the wall mount application, the rear connections will not pose a problem for pipe mounting. The connections on the 700.05 are far enough apart to enable a full sized 2 1/2" pipe to be used. If the customer wishes, a stainless steel offset plate is now available to hold the gauge off to the side of the pipe. The plate is U-bolted to the pipe and after the gauge and bracket assembly is bolted to the plate, the plate will hold the gauge away from the pipe.

4 1/2" Wall mount

The 4 1/2" uses the same sensor housing, mounting bracket, and U-bolts as the 2 1/2" gauge and will therefore encounter the same issues as indicated above. See the 2 1/2" section.

4 1/2" Pipe mount

Again, the 4 1/2" uses the same sensor housing, mounting bracket, and U-bolts as the 2 1/2" gauge and will therefore encounter the same issues as indicated above. See the 2 1/2" section.

Optional Mounting Accessories

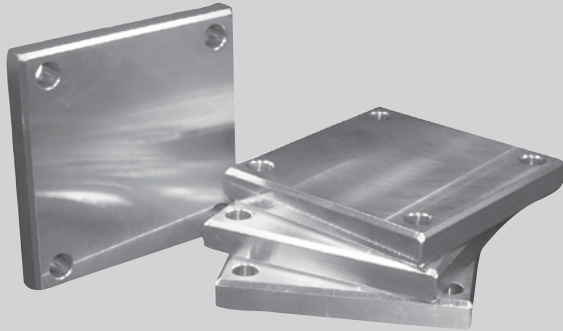

Standoff Block
part number: 50027611

Used to hold wall mounting bracket away from the wall in order to access the rear gauge connections.

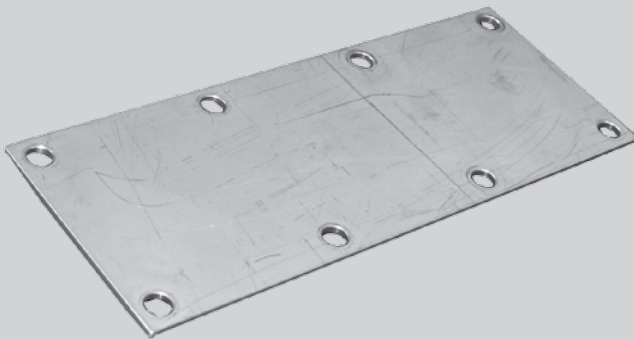
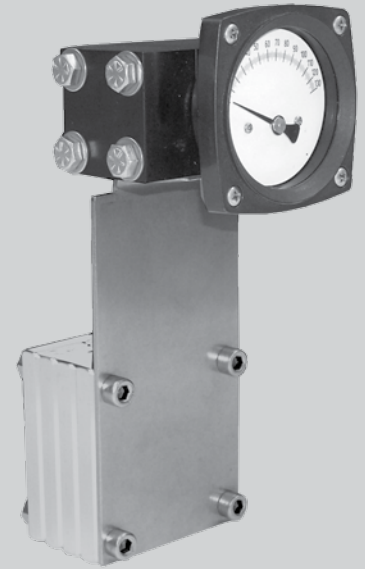

Pipe Mounting Offset Plate
part number: 50027620

Used to hold pipe mounting bracket away from pipe in order to access rear gauge connections.

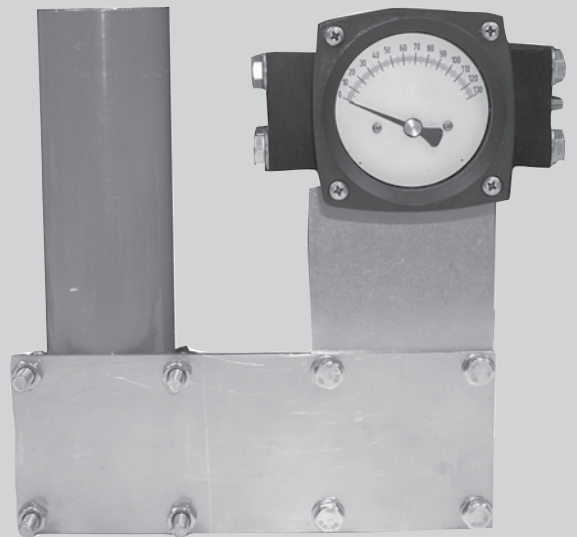

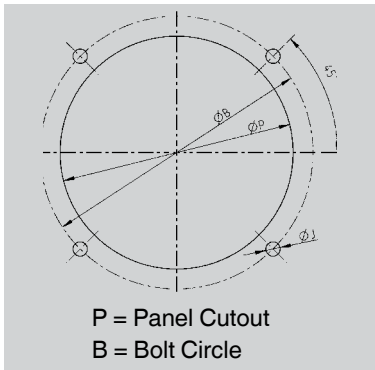

Panel Mouting- Rear Mount

Size		B	J	P
2½"	mm	89.6	4.7	76.8
	in	3.53	0.185	3.02

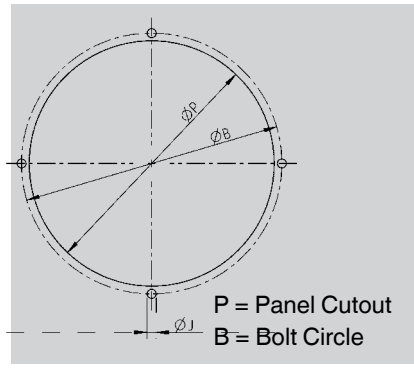

Panel Cutout, Panel Mouting- Rear Mount

Size		B	J	P
4½"	mm	143.4	4.7	133.4
	in	5.64	0.185	5.25

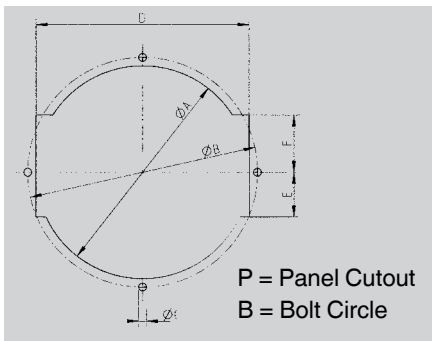

Panel Mouting- Surface Mount (4½" only)

Size		A	B	C	D	E	F
4½"	mm	133.4	143.4	4.7	133.4	27.9	35.6
	in	5.25	5.64	0.185	5.25	1.098	1.402

Note: 4 mouting studs, washer and nut supplied in plastic bag

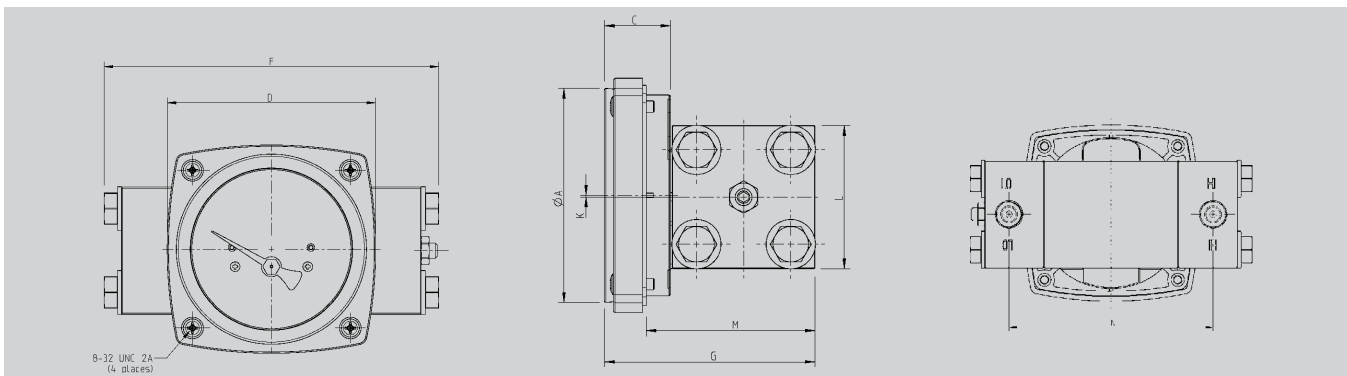

Size		ϕA	C	D	E	F	G	H	K	L	M	N	S
2½"	mm	76	23.5	83.2	25.1	133.6	74.8	5.7	0.6	50.8	60	96.5	3.2
	in	2.99	0.92	3.28	0.50	5.26	2.94	0.22	0.02	2.0	2.36	3.80	0.13

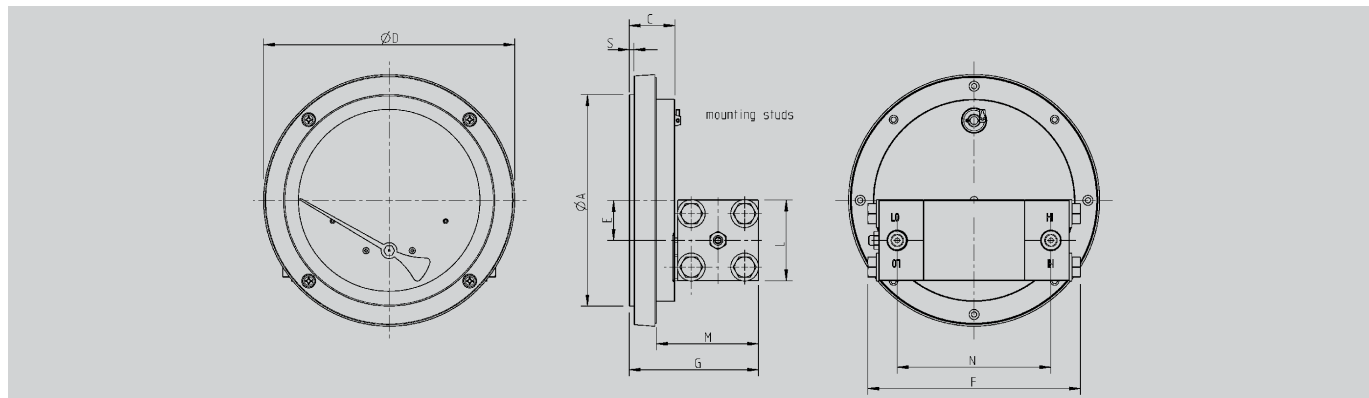

Size		$\varnothing A$	C	D	E	F	G	L	M	N	S
4½"	mm	132.4	28.8	157.7	25.1	133.0	79.32	50.8	64.1	96.5	2.9
	in	5.21	1.13	6.21	0.99	5.23	3.12	2.0	2.52	3.80	0.12

Notes: Panel Mounting

2½"

Surface mount

The 2½" gauge cannot be surface mounted in a panel due to the size of the sensor block.

2½" Rear mount

Must be a dry gauge with no drag pointer in order to rear mount in a panel. Do not loosen the screws of a filled gauge or leakage will result.

Remove bezel screws (dry gauge) to relax any deformation of the bezel and insert the bezel into the panel cutout. Connect the gauge case to the bezel again from the rear and secure with the original screws inserted from the front of the panel, screwing into the case behind the panel.

4½"

Surface mount

Surface mounting can be done with either dry gauges or filled gauges.

The 700.05 is provided with studs and nuts for panel mounting in the surface-mount position. After making the proper cutout, and installing the studs in the back of the gauge, install the gauge from the front and secure with the nuts provided with the gauge.

4½" Rear mount

Must be a dry gauge with no drag pointer in order to back mount. Do not loosen the screws of a filled gauge or leakage will result.

Remove bezel screws (dry gauge) to relax any deformation of the bezel and insert the bezel into the panel cutout. Connect the gauge case to the bezel again from the rear and secure with the original screws inserted from the front of the panel, screwing into the case behind the panel.

700.05 Weights

Aluminum	Dry		Filled	
2½"	2.2	lbs.	2.3	lbs.
4½"	2.5	lbs.	2.8	lbs.
Stainless	Dry		Filled	
2½"	5.0	lbs.	5.0	lbs.
4½"	5.3	lbs.	5.6	lbs.
Brass	Dry		Filled	
2½"	5.2	lbs.	5.3	lbs.
4½"	5.5	lbs.	5.9	lbs.

Operating and Installation Instructions

Gauge Inspection:

Please read the product specifications label attached to the gauge body to insure that this gauge is the same gauge specified for the particular application as it applies to dial size, materials of construction, working pressure, differential pressure, etc. Inspect for any shipping damage and, if discovered, report it immediately

Product Design Features:

The WIKA Type 700.05 Series is a magnetically coupled, convoluted diaphragm, differential pressure gauge. It is designed for use where particulate matter, carried in the system media, will not affect gauge performance, because there are no close internal tolerances in the sensor cell and there is total separation between the high (+) and low (-) sides of the gauge. Designed for working pressures to 3,000 psig and low to high differential pressure from 0-50" H₂O to 0-100 psid. The high side (+) pressure works against the diaphragm assembly and the calibrated DP range spring. A follower magnet, attached to the pointer, tracks the linear movement of this assembly. The pointer, in turn, indicates the differential pressure. The convoluted diaphragm is fully supported, in either direction, to the rated working pressure of the gauge.

Measuring system diagram

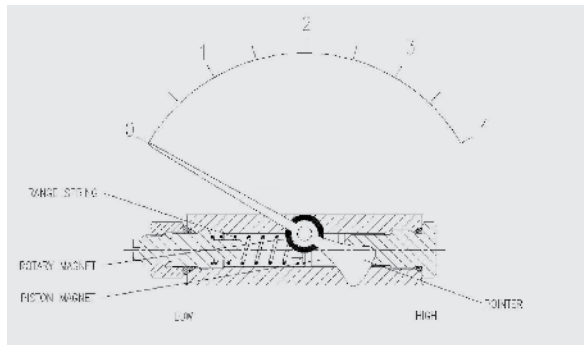

Ordering information
Pressure gauge model / Nominal size / Scale range / Size of connection / Optional extras required
Specifications and dimensions given in this leaflet represent the state of engineering at the time of printing.
Modifications may take place and materials specified may be replaced by others without prior notice.

Gauge Mounting:

This gauge is supplied, standard, for panel mounting. If installing the 2½" dial gauge, remove the four (4) bezel screws, mount the gauge from front to back in the panel, then reinsert the four (4) screws through the panel and into the bezel and tighten securely to the panel (Do not over-torque). If installing the 4½" dial gauge, mount the four (4) threaded studs into the back of the dial case, where indicated (Do not over-torque). Mount the gauge from front to back in the panel and secure the gauge to the panel with the locking nuts on the threaded studs. Optional pipe mount kits or wall mount kits are available. (Note: 2½" gauge cannot be panel mounted if case is liquid filled.)

Gauge Connections:

Standard (2) x ¼" FNPT back connections. Optional connection sizes and top, bottom or dual top/bottom connection is available

Troubleshooting:

If the gauge is not indicating differential pressure, check to insure both the high (+) and low (-) side connections have been properly installed. Check to insure that there is pressure to the high (+) side of the gauge and that there is differential pressure across the device being monitored by the Type 700.05 Series. If the system is being used together with a three-valve manifold, check to insure that the high (+) and low (-) valves are in the open position and the equalizer valve is in the closed position. If, after following these steps with no positive result, please contact the WIKA Customer Service Department or your nearest WIKA Distributor.

