

AWK-3131A-RCC Series

Industrial IEEE 802.11a/b/g/n wireless AP/client



Features and Benefits

- Designed specifically for rail carriage-to-carriage communication
- IEEE 802.11a/b/g/n compliant
- Up to 300 Mbps data rate
- M12 anti-vibration connectors
- MIMO technology increases data throughput and range
- Complies with all EN 50155 mandatory test items¹
- Wide-temperature models available for -40 to 75°C environments
- Supports the Auto Carriage-to-Carriage connection function

Certifications



Introduction

The AWK-3131A-RCC Series industrial 802.11n wireless AP/client is an ideal wireless solution for applications such as onboard passenger infotainment systems and inter-carriage wireless backbone networks because it provides a faster data rate compared to 802.11g devices. The auto carriage connection (ACC) feature easy deployment of wireless devices and increases the reliability of wireless carriage backbone networks. The AWK-3131A-RCC Series is also optimized for passenger Wi-Fi services and complies with a portion of the EN 50155 specifications covering operating temperature, power input voltage, surge, ESD, and vibration, making the products suitable for a variety of industrial applications. The AWK-3131A-RCC Series can also be powered via the PoE port for easier deployment.

High Data Rate and Bandwidth

- High-speed wireless connectivity with up to 300 Mbps data rate
- MIMO technology to improve the capability of transmitting and receiving multiple data streams
- Increased channel width with channel bonding technology

Designed for Industrial-grade Applications

- Industrial-grade QoS and VLAN for efficient data traffic management
- Integrated DI/DO for on-site monitoring and warnings
- Signal strength LEDs for easy deployment and antenna alignment

Specifications

WLAN Interface

WLAN Standards	802.11a/b/g/n 802.11i Wireless Security
Modulation Type	DSSS OFDM 802.11b: CCK @ 11/5.5 Mbps 802.11b: DQPSK @ 2 Mbps 802.11b: DBPSK @ 1 Mbps 802.11a/g: 64QAM @ 54/58 Mbps 802.11a/g: 16QAM @ 36/24 Mbps 802.11a/g: QPSK @ 18/12 Mbps 802.11a/g: BPSK @ 9/6 Mbps 802.11n: 64QAM @ 300 Mbps to BPSK @ 6.5 Mbps
Frequency Band for US (20 MHz operating channels)	2.412 to 2.462 GHz (11 channels)

1. This product is suitable for rolling stock railway applications, as defined by the EN 50155 standard. For a more detailed statement, click here: www.moxa.com/doc/specs/EN_50155_Compliance.pdf

	5.180 to 5.240 GHz (4 channels) 5.260 to 5.320 GHz (4 channels) ² 5.500 to 5.700 GHz (8 channels) excluding 5.600 to 5.640 GHz ³ 5.745 to 5.825 GHz (5 channels)
Frequency Band for EU (20 MHz operating channels)	2.412 to 2.472 GHz (13 channels) 5.180 to 5.240 GHz (4 channels) 5.260 to 5.320 GHz (4 channels) ² 5.500 to 5.700 GHz (11 channels) ³
Frequency Band for JP (20 MHz operating channels)	2.412 to 2.484 GHz (14 channels) 5.180 to 5.240 GHz (4 channels) 5.260 to 5.320 GHz (4 channels) ² 5.500 to 5.700 GHz (11 channels) ²
Wireless Security	SSID broadcast enable/disable WEP encryption (64-bit and 128-bit) WPA/WPA2-Personal WPA/WPA2-Enterprise (IEEE 802.1X/RADIUS, TKIP, AES)
Transmission Rate	802.11b: 1 to 11 Mbps 802.11a/g: 6 to 54 Mbps 802.11n: 6.5 to 300 Mbps
Transmitter Power for 802.11a	23±1.5 dBm @ 6 to 24 Mbps 21±1.5 dBm @ 36 Mbps 20±1.5 dBm @ 48 Mbps 18±1.5 dBm @ 54 Mbps
Transmitter Power for 802.11b	26±1.5 dBm @ 1 Mbps 26±1.5 dBm @ 2 Mbps 26±1.5 dBm @ 5.5 Mbps 25±1.5 dBm @ 11 Mbps
Transmitter Power for 802.11g	23±1.5 dBm @ 6 to 24 Mbps 21±1.5 dBm @ 36 Mbps 19±1.5 dBm @ 48 Mbps 18±1.5 dBm @ 54 Mbps
Transmitter Power for 802.11n (2.4 GHz)	23±1.5 dBm @ MCS0 20 MHz 21±1.5 dBm @ MCS1 20 MHz 21±1.5 dBm @ MCS2 20 MHz 21±1.5 dBm @ MCS3 20 MHz 20±1.5 dBm @ MCS4 20 MHz 19±1.5 dBm @ MCS5 20 MHz 18±1.5 dBm @ MCS6 20 MHz 18±1.5 dBm @ MCS7 20 MHz 23±1.5 dBm @ MCS8 20 MHz 21±1.5 dBm @ MCS9 20 MHz 21±1.5 dBm @ MCS10 20 MHz 21±1.5 dBm @ MCS11 20 MHz 20±1.5 dBm @ MCS12 20 MHz 19±1.5 dBm @ MCS13 20 MHz 18±1.5 dBm @ MCS14 20 MHz 18±1.5 dBm @ MCS15 20 MHz 23±1.5 dBm @ MCS0 40 MHz 20±1.5 dBm @ MCS1 40 MHz 20±1.5 dBm @ MCS2 40 MHz 20±1.5 dBm @ MCS3 40 MHz 19±1.5 dBm @ MCS4 40 MHz 19±1.5 dBm @ MCS5 40 MHz 18±1.5 dBm @ MCS6 40 MHz 17±1.5 dBm @ MCS7 40 MHz 23±1.5 dBm @ MCS8 40 MHz 20±1.5 dBm @ MCS9 40 MHz 20±1.5 dBm @ MCS10 40 MHz 20±1.5 dBm @ MCS11 40 MHz 20±1.5 dBm @ MCS12 40 MHz

2. DFS (Dynamic Frequency Selection) channel support: In AP mode, when a radar signal is detected, the device will automatically switch to another channel. However, according to regulations, after switching channels, a 60-second availability check period is required before starting the service.
3. DFS (Dynamic Frequency Selection) channel support: In AP mode, when a radar signal is detected, the device will automatically switch to another channel. However according to regulations, after switching channels, a 60-second availability check period is required before starting the service.

	<p>19±1.5 dBm @ MCS13 40 MHz 18±1.5 dBm @ MCS14 40 MHz 17±1.5 dBm @ MCS15 40 MHz</p>
Transmitter Power for 802.11n (5 GHz)	<p>23±1.5 dBm @ MCS0 20 MHz 20±1.5 dBm @ MCS1 20 MHz 20±1.5 dBm @ MCS2 20 MHz 20±1.5 dBm @ MCS3 20 MHz 19±1.5 dBm @ MCS4 20 MHz 18±1.5 dBm @ MCS5 20 MHz 18±1.5 dBm @ MCS6 20 MHz 18±1.5 dBm @ MCS7 20 MHz 23±1.5 dBm @ MCS8 20 MHz 20±1.5 dBm @ MCS9 20 MHz 20±1.5 dBm @ MCS10 20 MHz 20±1.5 dBm @ MCS11 20 MHz 19±1.5 dBm @ MCS12 20 MHz 19±1.5 dBm @ MCS13 20 MHz 18±1.5 dBm @ MCS14 20 MHz 18±1.5 dBm @ MCS15 20 MHz 23±1.5 dBm @ MCS0 40 MHz 20±1.5 dBm @ MCS1 40 MHz 20±1.5 dBm @ MCS2 40 MHz 20±1.5 dBm @ MCS3 40 MHz 19±1.5 dBm @ MCS4 40 MHz 18±1.5 dBm @ MCS5 40 MHz 18±1.5 dBm @ MCS6 40 MHz 18±1.5 dBm @ MCS7 40 MHz 23±1.5 dBm @ MCS8 40 MHz 20±1.5 dBm @ MCS9 40 MHz 20±1.5 dBm @ MCS10 40 MHz 20±1.5 dBm @ MCS11 40 MHz 19±1.5 dBm @ MCS12 40 MHz 19±1.5 dBm @ MCS13 40 MHz 18±1.5 dBm @ MCS14 40 MHz 18±1.5 dBm @ MCS15 40 MHz</p>
Receiver Sensitivity for 802.11a	<p>-90 dBm @ 6 Mbps -88 dBm @ 9 Mbps -88 dBm @ 12 Mbps -85 dBm @ 18 Mbps -81 dBm @ 24 Mbps -78 dBm @ 36 Mbps -74 dBm @ 48 Mbps -74 dBm @ 54 Mbps</p>
Receiver Sensitivity for 802.11b	<p>-93 dBm @ 1 Mbps -93 dBm @ 2 Mbps -93 dBm @ 5.5 Mbps -88 dBm @ 11 Mbps</p>
Receiver Sensitivity for 802.11g	<p>-88 dBm @ 6 Mbps -86 dBm @ 9 Mbps -85 dBm @ 12 Mbps -85 dBm @ 18 Mbps -85 dBm @ 24 Mbps -82 dBm @ 36 Mbps -78 dBm @ 48 Mbps -74 dBm @ 54 Mbps</p>
Receiver Sensitivity for 802.11n (2.4 GHz)	<p>-89 dBm @ MCS0 20 MHz -85 dBm @ MCS1 20 MHz -85 dBm @ MCS2 20 MHz -82 dBm @ MCS3 20 MHz -78 dBm @ MCS4 20 MHz -74 dBm @ MCS5 20 MHz -72 dBm @ MCS6 20 MHz -70 dBm @ MCS7 20 MHz -95 dBm @ MCS8 20 MHz -90 dBm @ MCS9 20 MHz -87 dBm @ MCS10 20 MHz -83 dBm @ MCS11 20 MHz -80 dBm @ MCS12 20 MHz</p>

	-74 dBm @ MCS13 20 MHz -71 dBm @ MCS14 20 MHz -69 dBm @ MCS15 20 MHz -87 dBm @ MCS0 40 MHz -83 dBm @ MCS1 40 MHz -83 dBm @ MCS2 40 MHz -80 dBm @ MCS3 40 MHz -76 dBm @ MCS4 40 MHz -73 dBm @ MCS5 40 MHz -69 dBm @ MCS6 40 MHz -67 dBm @ MCS7 40 MHz -93 dBm @ MCS8 40 MHz -88 dBm @ MCS9 40 MHz -85 dBm @ MCS10 40 MHz -82 dBm @ MCS11 40 MHz -78 dBm @ MCS12 40 MHz -73 dBm @ MCS13 40 MHz -69 dBm @ MCS14 40 MHz -67 dBm @ MCS15 40 MHz
Receiver Sensitivity for 802.11n (5 GHz)	-88 dBm @ MCS0 20 MHz -85 dBm @ MCS1 20 MHz -82 dBm @ MCS2 20 MHz -79 dBm @ MCS3 20 MHz -76 dBm @ MCS4 20 MHz -71 dBm @ MCS5 20 MHz -70 dBm @ MCS6 20 MHz -69 dBm @ MCS7 20 MHz -95 dBm @ MCS8 20 MHz -91 dBm @ MCS9 20 MHz -87 dBm @ MCS10 20 MHz -80 dBm @ MCS11 20 MHz -78 dBm @ MCS12 20 MHz -74 dBm @ MCS13 20 MHz -72 dBm @ MCS14 20 MHz -71 dBm @ MCS15 20 MHz -84 dBm @ MCS0 40 MHz -81 dBm @ MCS1 40 MHz -77 dBm @ MCS2 40 MHz -75 dBm @ MCS3 40 MHz -71 dBm @ MCS4 40 MHz -67 dBm @ MCS5 40 MHz -64 dBm @ MCS6 40 MHz -63 dBm @ MCS7 40 MHz -90 dBm @ MCS8 40 MHz -85 dBm @ MCS9 40 MHz -82 dBm @ MCS10 40 MHz -81 dBm @ MCS11 40 MHz -77 dBm @ MCS12 40 MHz -73 dBm @ MCS13 40 MHz -71 dBm @ MCS14 40 MHz -68 dBm @ MCS15 40 MHz
WLAN Operation Mode	Access point, Client, Client-Router, Sniffer
Antenna Connectors	QMA
Ethernet Interface	
PoE Ports (10/100/1000BaseT(X), M12 A-coded 8-pin female connector)	1
Standards	IEEE 802.3 for 10BaseT IEEE 802.3u for 100BaseT(X) IEEE 802.3ab for 1000BaseT IEEE 802.3af for PoE IEEE 802.1Q for VLAN Tagging
10/100/1000BaseT(X) Ports (M12 A-coded 8-pin female connector)	1, M12 A-coded 8-pin female connector, 10/100/1000BaseT(X) auto negotiation speed, F/H duplex mode, auto MDI/MDI-X connection

Ethernet Software Features

Management	General: Proxy ARP, DNS, HTTP, HTTPS, IP, ICMP, SNTP, TCP, UDP, RADIUS, SNMP, DHCP AP-only: ARP, BOOTP, DHCP
Security	RADIUS
Firewall	
Filter	MAC/IP Protocol/Port-based
Serial Interface	
Console Port	RS-232 (RJ45-type)
LED Interface	
LED Indicators	PWR1, PWR2, PoE, FAULT, STATE, SIGNAL, Client, WLAN, LAN
Input/Output Interface	
Digital Inputs	2 +13 to +30 V for state 1 +3 to -30 V for state 0 Max. input current: 8 mA
Alarm Contact Channels	Relay output with current carrying capacity of 1 A @ 24 VDC
Buttons	Reset button
Physical Characteristics	
Housing	Metal
IP Rating	IP30
Dimensions	52.9 x 151.9 x 127.4 mm (2.08 x 5.98 x 5.02 in)
Weight	850 g (1.87 lb)
Installation	DIN-rail mounting, Wall mounting (with optional kit)
Power Parameters	
Input Current	0.67 A @ 12 VDC, 0.17 A @ 48 VDC
Input Voltage	12 to 48 VDC, Redundant dual inputs, 48 VDC Power-over-Ethernet
Power Connector	1 removable 10-contact terminal block(s)
Power Consumption	Maximum 8.03 W
Reverse Polarity Protection	Supported
Environmental Limits	
Operating Temperature	Standard Models: -25 to 60°C (-13 to 140°F) Wide Temp. Models: -40 to 75°C (-40 to 167°F)
Storage Temperature (package included)	-40 to 85°C (-40 to 185°F)
Ambient Relative Humidity	5 to 95% (non-condensing)
Standards and Certifications	
EMC	EN 55032/24
EMI	CISPR 32, FCC Part 15B Class B
EMS	IEC 61000-4-2 ESD: Contact: 8 kV; Air: 15 kV

	IEC 61000-4-3 RS: 80 MHz to 1 GHz: 20 V/m IEC 61000-4-4 EFT: Power: 2 kV; Signal: 2 kV IEC 61000-4-5 Surge: Power: 2 kV; Signal: 2 kV IEC 61000-4-6 CS: 10 V IEC 61000-4-8 PFMF
Railway	EN 50155, EN 50121-4
Railway Fire Protection	EN 45545-2
Radio	EN 300 328, EN 301 893, MIC, FCC ID SLE-WAPN008, IDA
Safety	UL 60950-1, IEC 60950-1, EN 60950-1 (LVD)

MTBF

Time	742,649 hrs
Standards	Telcordia SR332

Warranty

Warranty Period	5 years
Details	See www.moxa.com/warranty

Package Contents

Device	1 x AWK-3131A-M12-RCC wireless AP/client
Installation Kit	1 x DIN-rail kit 2 x cap, plastic, for RJ45 port 1 x cable holder with screw
Documentation	1 x quick installation guide 1 x warranty card

Dimensions

Unit: mm (inch)

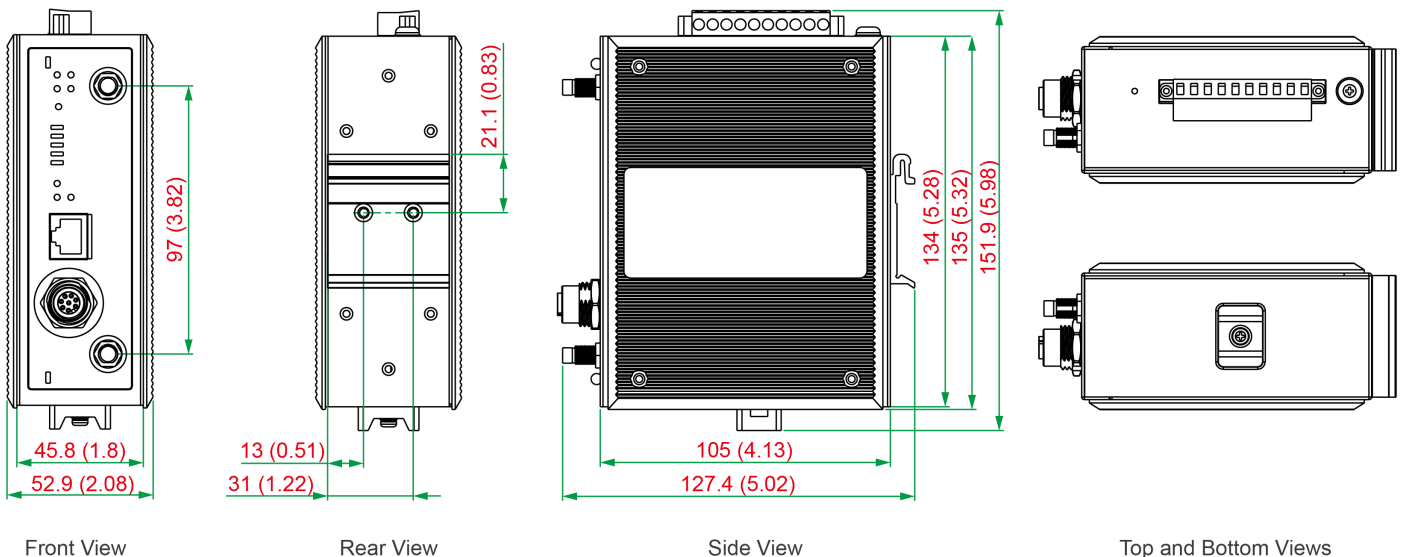

Ordering Information

Model Name	Band	Operating Temperature (-40 to 75°C)	Conformal Coating
AWK-3131A-M12-RCC-US	US	-25 to 60°C	-
AWK-3131A-M12-RCC-EU	EU	-25 to 60°C	-

Model Name	Band	Operating Temperature (-40 to 75°C)	Conformal Coating
AWK-3131A-M12-RCC-JP	JP	-25 to 60°C	-
AWK-3131A-M12-RCC-US-T	US	-40 to 75°C	-
AWK-3131A-M12-RCC-EU-T	EU	-40 to 75°C	-
AWK-3131A-M12-RCC-JP-T	JP	-40 to 75°C	-
AWK-3131A-M12-RCC-US-CT	US	-25 to 60°C	✓
AWK-3131A-M12-RCC-EU-CT	EU	-25 to 60°C	✓
AWK-3131A-M12-RCC-JP-CT	JP	-25 to 60°C	✓
AWK-3131A-M12-RCC-US-CT-T	US	-40 to 75°C	✓
AWK-3131A-M12-RCC-EU-CT-T	EU	-40 to 75°C	✓
AWK-3131A-M12-RCC-JP-CT-T	JP	-40 to 75°C	✓

Accessories (sold separately)

Wall-Mounting Kits

WK-51-01	Wall-mounting kit, 2 plates, 6 screws, 51.6 x 67 x 2 mm
----------	---

© Moxa Inc. All rights reserved. Updated Jan 17, 2019.

This document and any portion thereof may not be reproduced or used in any manner whatsoever without the express written permission of Moxa Inc. Product specifications subject to change without notice. Visit our website for the most up-to-date product information.