



# DATASHEET

EYES

V1.0

# Datasheet

## Eyes

Camera Characteristics	
Interface	USB-C 3.x
Image Sensor Technology	Rolling Shutter. 1.4µm x 1.4µm pixel size
RGB Camera Field of View (FOV)	69.4° x 42.5° x 77° (+/- 3°)
RGB Camera Resolution	1280x1080
Depth Technology	Active IR Stereo
Depth FOV	65°±2° x 40°±1° x 72°±2°
Depth Output Resolution	1280 x 720
Working Distance	400-1000 mm
Operating Temperature	0 – 35 °C
IP Rating	IP 65

Eyes Features		
Type of vision system	2.5 D	
Minimum part size	10x10 mm or 15 mm diameter	
Applications Supported	Detection, Sorting	
Mounting options supported	Robot and External	
Reconfigurability when Robot mounted	12 configurations (4 x 3)	
	Around robot's flange	Tilt orientations
	0 - 90 - 180 - 270 (degrees)	0 - 45 - 90 (degrees)
Processing time	Typical: 0.5 s	
Detection Repeatability	< 2 mm	
Detection Accuracy	External Mount	Robot Mount
	Typical: 2 mm	Typical: 2 mm

Application and set-up recommendations	
Lighting conditions	No drastic, instant changes
Reflections and focused light spots	Keep minimal
Characteristics of objects	Different from background
Camera with respect to workspace table	Looking straight to it

**Robot Mount**

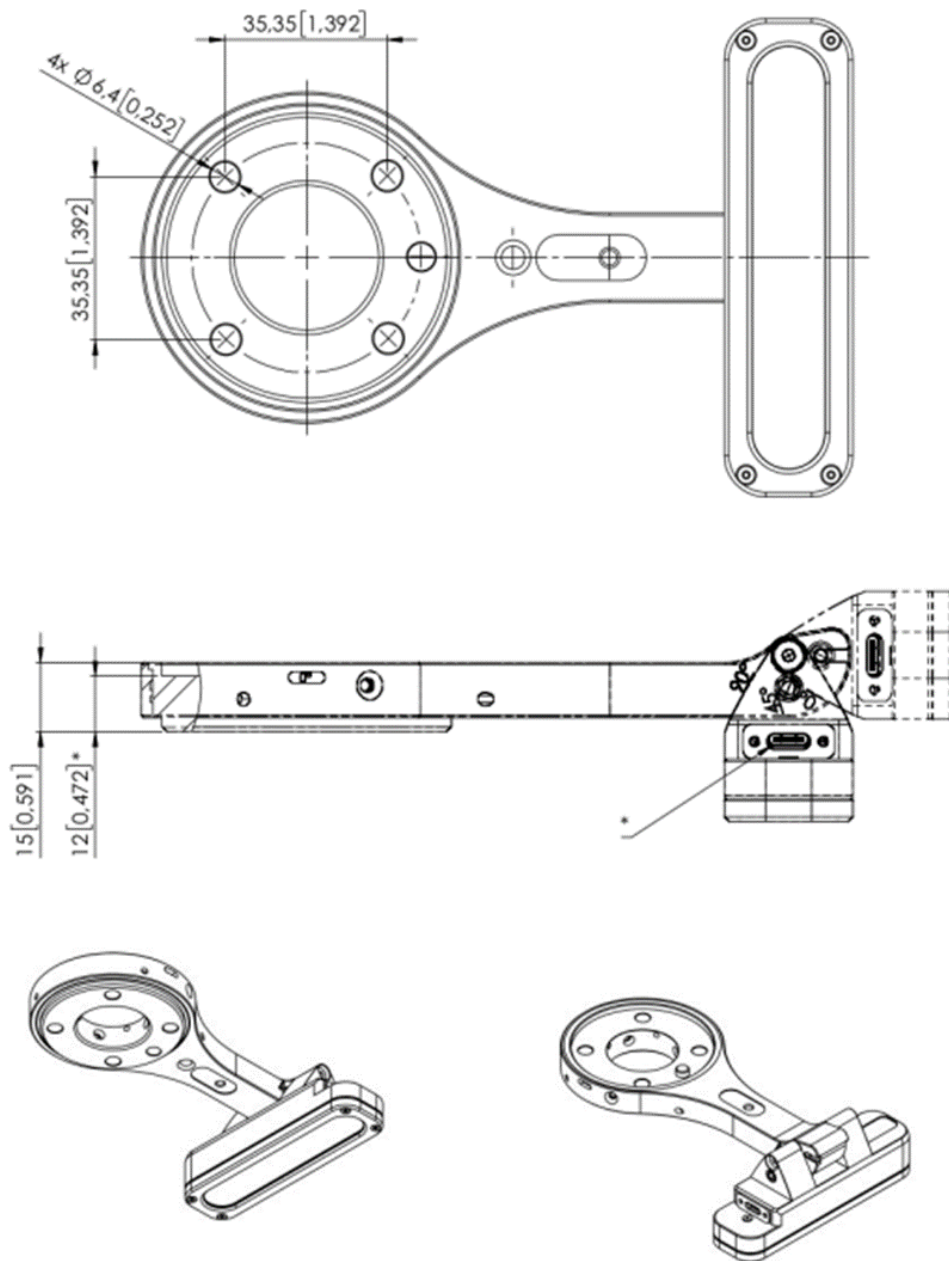

All dimensions are in mm and [inches].

**External Mount**

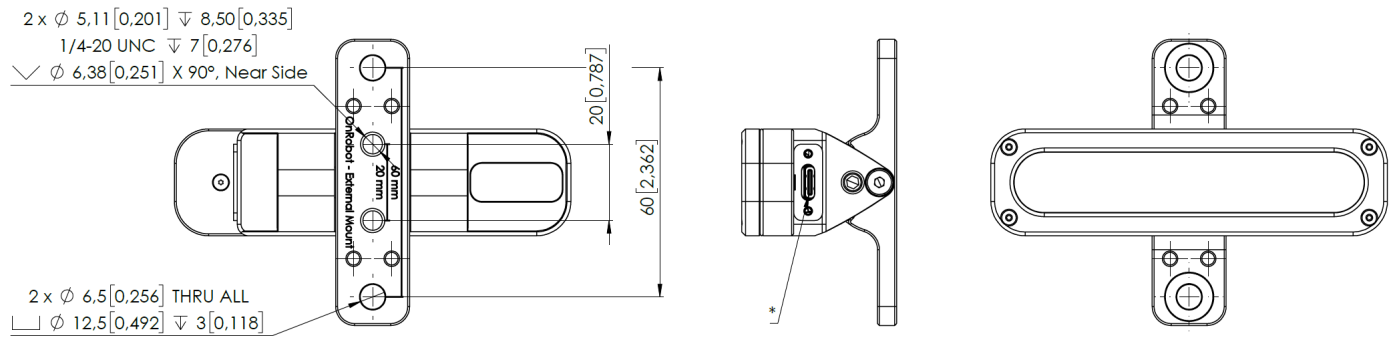

All dimensions are in mm and [inches].