

# Low Pressure Gauge Type 612.20, Stainless Steel Case

WIKA Datasheet 612.20

## Applications

- Low pressure pneumatic systems
- Suitable for fluid medium, gaseous or dry that does not corrode copper alloy.

## Product features

- Low pressure series
- Copper alloy wetted parts & stainless steel case
- Capsule pressure gauge

## Specifications

### Design

EN 837-3

### Size

2½", 4" & 6" (63 mm, 100 mm & 160 mm)

### Accuracy class

± 1.5% of span

### Ranges (All ranges not stocked)

Size 2½" (63 mm): 0 ... 10" H<sub>2</sub>O (25 mbar) to 0 ... 250" H<sub>2</sub>O (600 mbar)

Size 4" (100 mm): 0 ... 4" H<sub>2</sub>O (10 mbar) to 0 ... 250" H<sub>2</sub>O (600 mbar)

Size 6" (160 mm): 0 ... 2.5" H<sub>2</sub>O (4 mbar) to 0 ... 250" H<sub>2</sub>O (600 mbar)

or all other equivalent vacuum or compound ranges

### Connection

Copper alloy

Size 2½" (63 mm): ¼" NPT lower mount (LM) or center back mount (CBM)

Size 4" & 6" (100 mm & 160 mm): ¼" NPT or ½" NPT lower mount (LM) or lower back mount (LBM)

### Capsule Element

Material: copper alloy

### Movement

Copper alloy, nickel-silver pinion gear and shaft.

Zero adjustment screw on dial

### Dial

White aluminum with black lettering

### Pointer

Black aluminum (zero adjust on dial. Must remove window to access)



## Pressure Gauge 612.20

### Case

304 stainless steel with stainless steel bayonet ring

### Weather Protection

Weather resistant (NEMA 3 / IP 54)

### Standard Scales

in. H<sub>2</sub>O/mm H<sub>2</sub>O  
oz.-sq. in./mm H<sub>2</sub>O  
oz.-sq. in./in. H<sub>2</sub>O  
PSI

### Window Gasket

Buna-N

### Window

Flat window glass

### Working Range

Steady: Full scale value  
Fluctuating: 0.9 x full scale value

### Operating Temperature

Ambient: -4°F to 140°F (-20°C to 60°C)

Media: max. 212°F (+100°C)

max. 176°F (+80°C) for 4" & 6" LBM

### Temperature error

Additional error when temperature changes from reference temperature of 68°F (20°C) ±0.6% of span for every 18°F (10°K) rising or falling.

## Optional Extras

- Front stainless steel polished
- Brass threaded restrictor
- U-Clamp bracket steel zinc plated with stainless steel polished profile ring (4" & 6")
- Safety glass window
- Overpressure and underpressure protection:
  - ≤ 10" H<sub>2</sub>O (25 mbar): 3x of full scale
  - > 10" H<sub>2</sub>O (25 mbar): 10x of full scale
- Cleaned for oxygen service
- Medical specification
- Special connections limited to wrench flat area
- Nickel plated connection
- Externally adjustable red mark pointer (set pointer)
- Externally adjustable red drag pointer (max. pointer)
- Custom dial layout
- Other pressure scales available

## Dimensions

### Standard versions

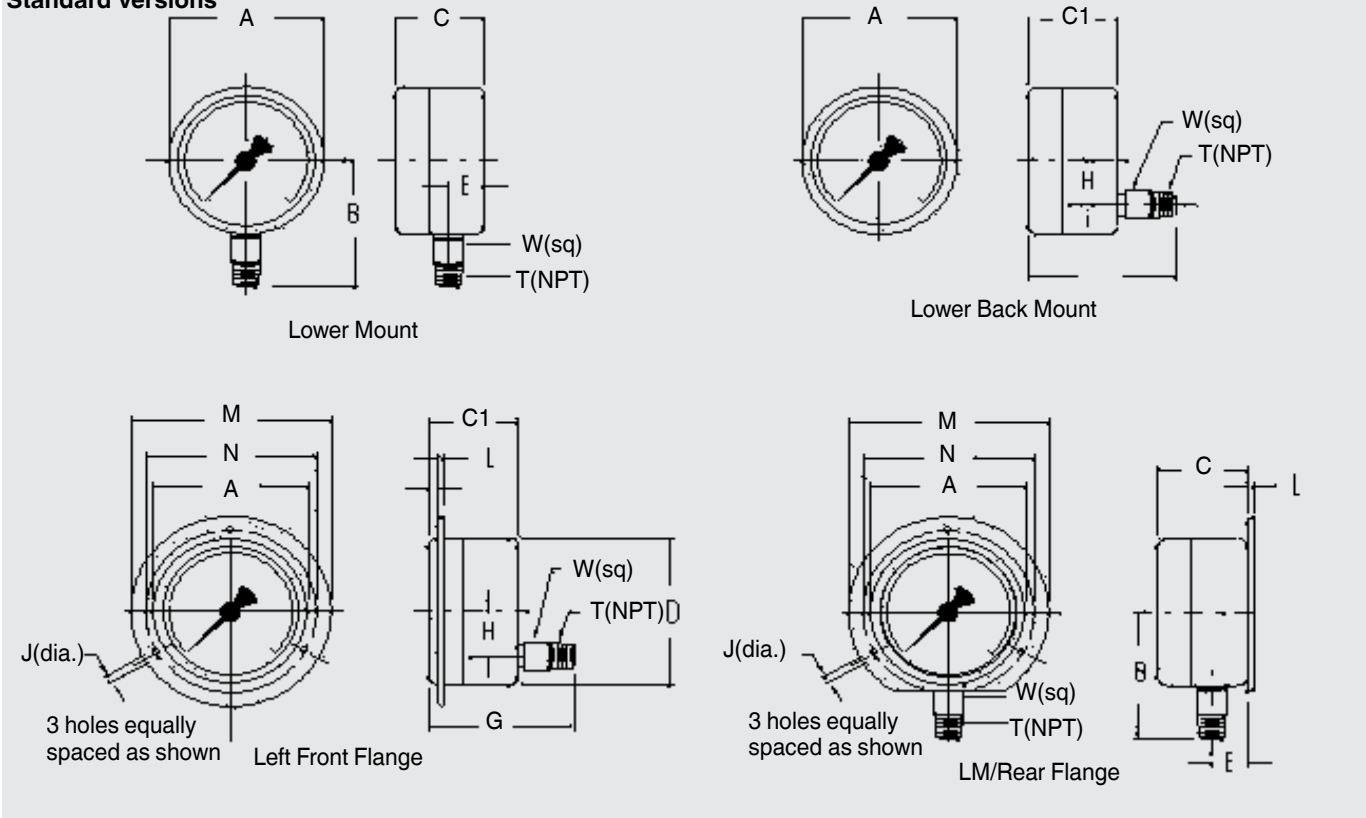

### A\* NOMINAL SIZE

TYPE/SIZE	WEIGHT	KEY	A	B	C	C1	D	E	G	H	J	L	M	N	T	W
612.20	1.32 lbs	mm	101	85	49.3	49.3	104	15.5	78	30	4.8	3	132	116	1/2" or 1/4"	22
4"		in	4	3.35	1.94	1.94	4.09	0.61	3.07	1.18	0.19	0.12	5.2	4.57	1/2" or 1/4"	0.86

Note: For 1/4" NPT connections, B dimension changes to 80mm / 3.15 in.  
Recommended panel cut-out: D + 1mm

### Ordering information

State computer part number (if available) /type number/size/range/connection size and locations/options required. WIKA reserves the right to make changes without prior notice.



**WIKAI Instrument Corporation**  
 1000 Wiegand Boulevard  
 Lawrenceville, GA 30043  
 1-888-WIKA-USA /770-513-8200 (in GA)  
 Fax 770-338-5118  
 info@wika.com www.wika.com