

Differential Pressure Gauges Membrane Sensing Element Type 732.25 - NACE MR-01-75 Compliant

WIKA Data Sheet APM 732.25

Applications

- For use in measurement applications requiring high differential / static process pressures.
- For corrosive environments with either liquid or gaseous media.

Product features

- External zero point adjustment
- Membrane sensing element
- Black powder-coated aluminum case
- 3000 psid maximum working pressure
- Differential pressure ranges to 600 psid

Description

Nominal Sizes

4½" (115 mm)
6" (160 mm)

Accuracy (on increasing pressure)

± 1% of span

Scale Ranges

0/100" H₂O through 0/600 psid
(250 mbard through 40 bard)

Maximum Safe Working Pressure (Overpressure Safety)

3000 psig (200 barg)

Operating Temperature

Ambient: -40°F to +200°F (-40°C to +93.3°C)
Media: max +100°C (+212°F)

Weather protection

NEMA 4X (IP66)



Differential Pressure Gauge Model 732.25 4½" & 6"

Standard features

Pressure connections

Standard:

1/4" NPT female, back connection (panel mounting only; wall & pipe mounting bracket is not compatible with back connection).

Optional:

1/4" NPT female, top & bottom.

1/2" NPT female, back connections with adapters (panel mounting only; wall & pipe mounting bracket is not compatible with back connection).

1/2" NPT female, dual connections, top and bottom with adapters.

Pressure connection markings

(+) High side connection; (-) Low side connection

Sensing Element (Wetted Parts)

Housing: 316L stainless steel

Membranes: Inconel® 718 (NiCr-alloy)/316L stainless steel

O-rings: Viton

NACE MR-01-75 compliant

Movement

Stainless steel

System Fill

Silicone Oil

Dial Case

Black powder-coated aluminum

Bezel Ring

Stainless steel polished

Dial

White aluminum with black lettering - standard

Pointer

Black aluminum

Window

Polycarbonate

Standard Scale

PSID

Zero Adjustment

External through top of case (allen wrench included)

Dial Case Filling

Glycerine 99.7% (Changes to Model 733.25)

Other filling fluids available as an option

Mounting

Panel mounting kit is included. Wall or pipe mount kit is available as an option, but is only compatible with the top/bottom connection.

Warranty

Seven (7) years limited

Order Options (min. order may apply)

- Black dial and white pointer
- Laminated safety glass window
- Stainless steel case
- Special connections
- Wall or pipe mounting kit
- Other pressure scales
- Handwritten calibration test report

Size		A
4½"	mm	157.2
	in	6.19
6"	mm	204.3
	in	8.04

Optional Wall Mounting Kit

(compatible only with optional top/bottom connections)

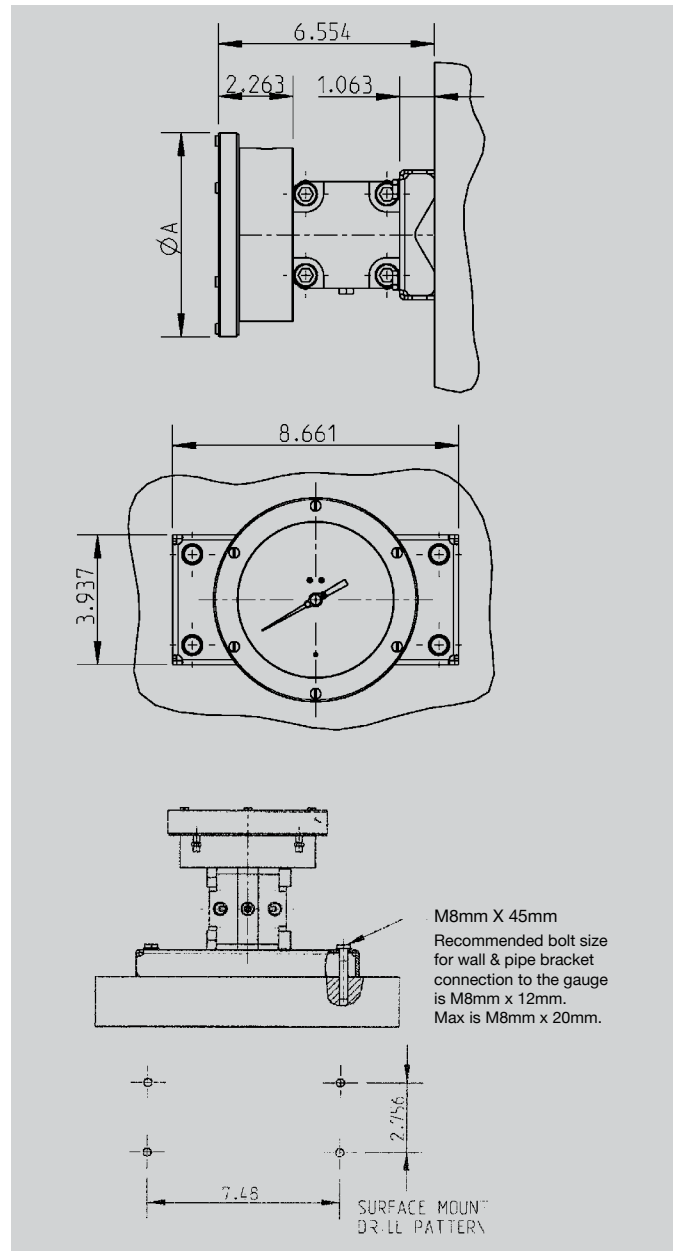

Optional Pipe Mounting Kit

(compatible only with top/bottom connections)

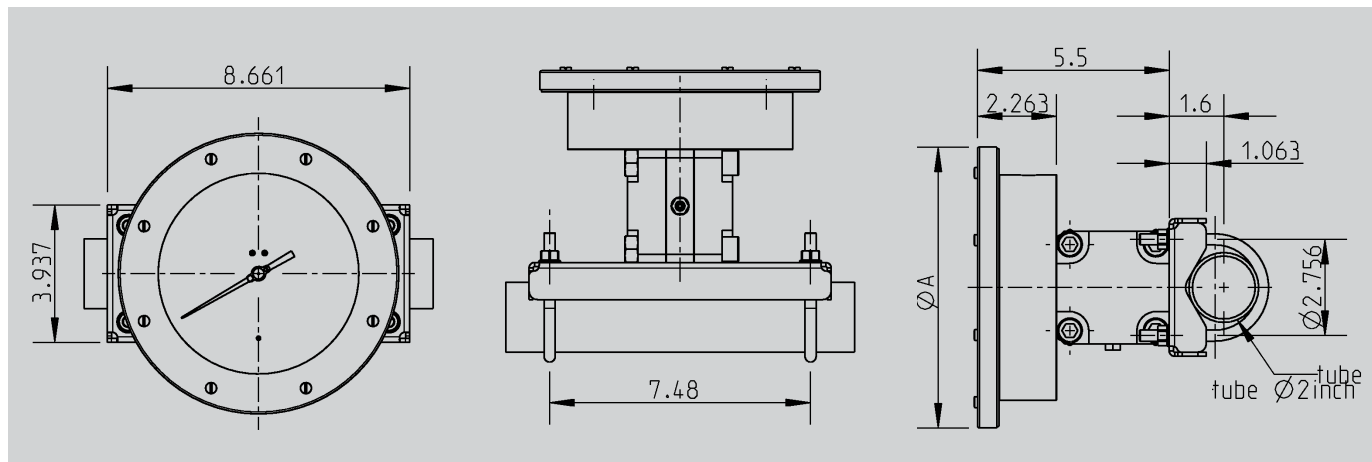

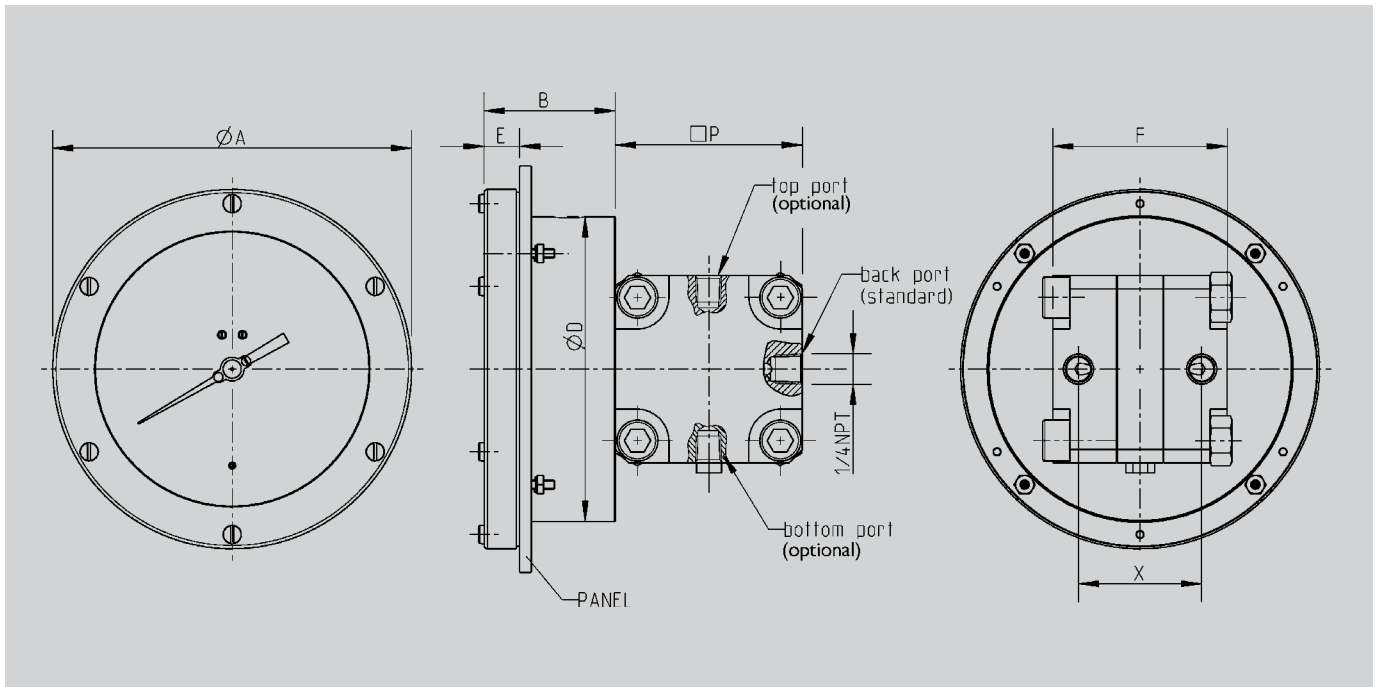

Size		$\varnothing A$	B	$\varnothing D$	E	F	$\square P$	X	Weight ¹
4½"	mm	157.3	57.5	133.4	25.1	80	82	54	10.75 lb. dry
	in	6.19	2.26	5.25	0.99	3.15	3.23	2.13	12.25 lb. filled
6"	mm	204.3	57.5	163.8	15.6	80	82	54	11.35 lb. dry
	in	8.04	2.26	6.45	0.61	3.15	3.23	2.13	13.65 lb. filled

¹ Weight without optional accessories

Zero Point Adjustment

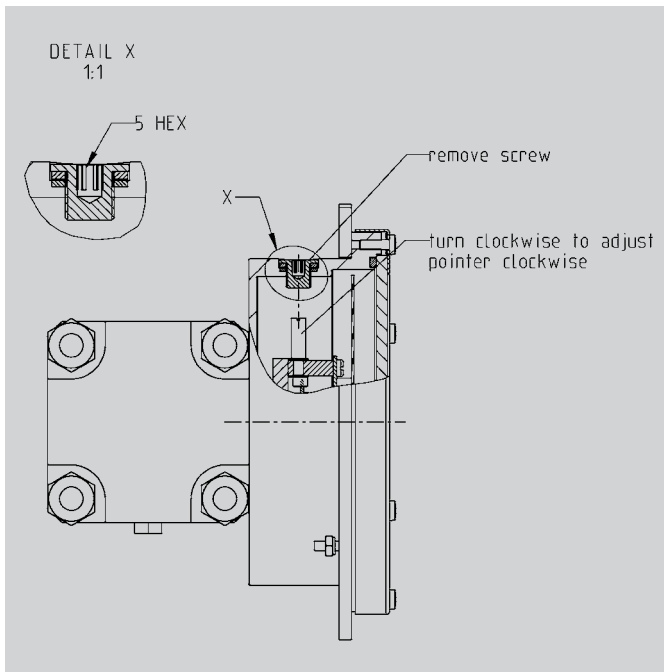

Panel Cut-out Dimensions

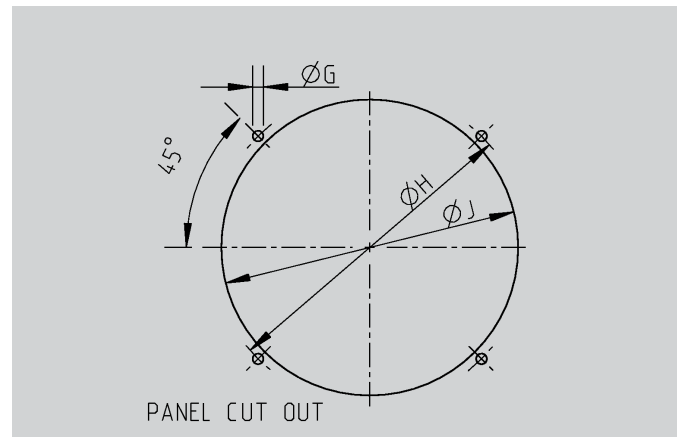

Size		$\varnothing G$	$\varnothing H$	$\varnothing J$
4½"	mm	4.8	143	134.3
	in	0.19	5.63	5.29
6"	mm	4.8	177.8	165
	in	0.19	7	6.5

Operating and Installation Instructions

Gauge Inspection:

Please read the product specification label attached to the gauge body to insure that this gauge is the same gauge specified for the particular application as it applies to dial size, materials of construction, working pressure, differential pressure, etc. Inspect for any shipping damage and, if discovered, report it immediately.

Product Design Features:

The Type 732.25 Series is designed for working pressures to 3,000 psig, with an over-range pressure and differential pressures to 600 psid. This series is supplied, standard, with a 4.5" dial or, optionally, with a 6" dial. The gauge has a 316L sensor cell, encapsulating opposed, high (+) and low (-) side Monel membranes in a Halocarbon fill. The high (+) side pressure works against the membranes and the fill, causing them to move. This movement is transferred to a torque-tube assembly, linked to a horizontally moving, bidirectional overpressure valve (This valve protects the sensor membranes against damage from high (+) and low (-) side overpressure of the membranes in the sensor cell.) A torsion rod, located within the torque-tube assembly, passes through a sealed compression fitting (which isolates the sensor cell from the dial case assembly) into the dial case and is connected to a pinion/sector gear and pointer assembly. The twisting motion of the torsion rod, driven by the membrane movement, is magnified to a 270 Degree, linear arc and pointer travel.

Design and Operating Principle

- Process pressures p_1 and p_2 are applied to the chambers - (2) and + (3).
- Gauge head (4) is filled with liquid.
- Differential pressure across + and - pressure sides deflects the diaphragm (1) and displaces the liquid.
- The displacement of the connection rod (5) is converted through the use of a transmitting lever (6) into rotation, which is transferred over an axial shaft (7) to the movement (9).
- The torque pipe (8) seals, assuring a frictionless path.
- Overpressure protection in both directions up to the max. Static pressure rating is provided by contoured metal bolsters.

Gauge Mounting:

The gauge is supplied, standard, for panel mounting. The mounting method is from front to back in the panel and the gauge is secured in the panel with four (4) threaded studs, supplied with the gauge. Optional pipe or wall mount kits are available. (See back)

Gauge Connections:

Standard (2) x 1/4" FNPT back connections with high (+) and low (-) connections clearly indicated. Optional connection sizes and/or dual top/bottom connections are available.

Troubleshooting:

If the gauge is not indicating differential pressure, check to insure both the high (+) and low (-) side connections have been properly installed. Check to insure that there is pressure to the high (+) side of the gauge and that there is differential pressure across the device being monitored by the Type 732.25 Series. If the gauge is being used together with a three-valve manifold (recommended), check to insure that the high (+) and low (-) valves are in the open position and the equalizer valve is in the closed position. If, after following these steps with no positive result, please contact the WIKA Customer Service Department or your nearest WIKA Distributor.

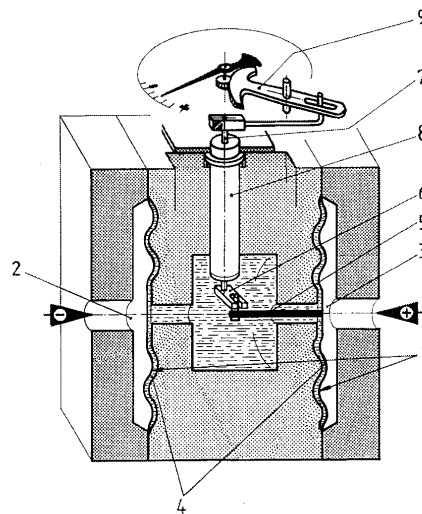

Ordering information

Pressure gauge model / Nominal size / Scale range / Size of connection / Optional extras required.
Specifications and dimensions given in this leaflet represent the state of engineering at the time of printing.
Modifications may take place and materials specified may be replaced by others without prior notice.



WIKA Instrument, LP
1000 Wiegand Boulevard
Lawrenceville, GA 30043-5868
Tel: 888-WIKA-USA • 770-513-8200
Fax: 770-338-5118
E-Mail: info@wika.com
www.wika.com