

Precision digital pressure gauge Model CPG1000

WIKA data sheet CT 10.01



Applications

- Oil and gas industry
- Maintenance and service facilities
- Calibration service companies and service industry
- Simple calibrations directly on site

Special features

- Measuring ranges from 0 ... 70 mbar up to 0 ... 700 bar (vacuum and absolute pressure ranges also available)
- Accuracy: 0.05 % (incl. calibration certificate)
- Intrinsically safe version, II 3G Ex nA IIB T6
- Rugged stainless steel case to NEMA 4/IP 65
- Software and complete service cases (incl. pumps) available

Description

General information

The model CPG1000 precision digital pressure gauge takes the concept of an analogue gauge, and takes it to a level only matched by digital calibrators. The accuracy of digital measurement technology and the simplicity of an analogue gauge are brought together in the CPG1000, which in terms of performance, ease-of-use, and instrument features, is unmatched in the pressure measurement market.

Accuracy

The CPG1000 offers an accuracy of 0.05 % of span in 14 pressure ranges. It is temperature compensated between 0 ... 50 °C. Readings can be displayed in one of 21 standard units or also in customer-specific units, so that awkward conversions are avoided.

Sampling rate

The measuring rate can be user-defined to match the type of measurement required. Standard applications usually use three measured values per second. If required, this rate can also be set to ten measured values per second.



Precision digital pressure gauge model CPG1000

Via an energy-saving function, the CPG1000 switches automatically into "sleep" mode. With this, the battery life increases to up to 2,000 hours.

Features

With the MIN/MAX function, the highest and lowest pressures that have been automatically recorded by the CPG1000 can be immediately retrieved. An automatic power-off function can be activated after a predefined time interval in order to extend battery life.

The ZERO and TARE functions compensate for any sensor drift. Password protection for on-site calibration can be activated via the CPG1000 keypad.

An RS-232 serial interface enables data for offline analysis to be read directly from the measuring instrument. An optional, external 24 V power supply input is available for the user, for when the CPG1000 is permanently built in to a process chain. The selectable damping function helps stabilise strongly-fluctuating pressures and makes them easier to read.

Software

In addition to the CPGLog data-logger evaluation software for the tabular and graphical representation of the logged data, WIKA-CAL calibration software for calibration tasks is also available. WIKA-CAL also offers, over and above PC-supported calibration, the management of the calibration and instrument data in an SQL database. For data transfer, an RS-232 interface is available.

Certified accuracy

For each digital pressure gauge, the accuracy is certified by a factory calibration certificate which accompanies the instrument. On request, we can provide a DKD/DAkkS calibration certificate for this instrument.

Specifications Model CPG1000

Sensor technology								
Measuring range	mbar	0 ... 70 ¹⁾						
Overpressure limit	mbar	200						
Burst pressure	mbar	350						
Resolution	mbar	0.001						
Measuring range	bar	0 ... 1	0 ... 2	-1 ... +1 ¹⁾	-1 ... +2 ¹⁾	0 ... 7		
Overpressure limit	bar	4	4	4	4	14		
Burst pressure	bar	6	6	6	6	70		
Resolution	bar	0.0001						
Measuring range	bar	0 ... 20	0 ... 35	0 ... 70	0 ... 140	0 ... 200	0 ... 350	0 ... 700
Overpressure limit	bar	42	70	140	210	420	700	1,100
Burst pressure	bar	140	140	700	700	700	700	1,100
Resolution	bar	0.001			0.01			
Measuring range	bar abs.	0 ... 1	0 ... 2	0 ... 7	0 ... 20			
Overpressure limit	bar abs.	4	4	14	42			
Burst pressure	bar abs.	35	35	70	140			
Resolution	bar abs.	0.0001			0.001			
Accuracy	0.05 % FS (0.1 % FS for measuring ranges 0 ... 70 mbar, -1 ... +1 bar and -1 ... +2 bar) (0.25 % FS for vacuum measuring ranges with instruments from 7 bar to a 700 bar) ²⁾							
Compensated temperature range	0 ... 50 °C							
Temperature coefficients	0.005 % of the span/°C outside of 0 ... 50 °C							
Type of pressure	relative pressure, absolute pressure (up to 20 bar abs) and vacuum measuring ranges							
Process connection	¼ NPT male (incl. ¼ NPT female to G ½ male adapter) ³⁾							
Pressure medium	all liquids and gases compatible with 316 stainless steel ¹⁾							

1) Only use with clean non-corrosive gases.

2) For measuring instruments with a maximum measuring range of up to 2 bar, operation in the vacuum measuring range is limited to -350 mbar. (Measuring ranges -1 ... +1 bar and -1 ... +2 bar are excluded.) Measuring ranges ≥ 7 bar can be loaded with a full vacuum.

3) Adapter not included in delivery for North America.

Base instrument

Indicator

Display	5 digit display, character size 16.53 mm (0.65") 20 segment bargraph, 0 ... 100 %
Pressure units	psi, bar, mbar, Kg/cm ² , inH ₂ O (4 °C, 20 °C or 60 °F), ftH ₂ O (4 °C, 20 °C or 60 °F), cmH ₂ O (4 °C and 20 °C), mH ₂ O (4 °C and 20 °C), kPa, MPa, inHg, mmHg, TORR, mSW, ft SW, user-defined unit

Functions

Measuring rate	0.5/sec. to 10/sec. selectable
Memory	MIN/MAX, integrated data logger
Data logger ⁴⁾	Cyclic logger: automatic recording of up to 8,500 values; Cycle time: selectable from 1...3,600 sec. in the following steps 1 s, 2 s, 5 s, 10 s, 30 s, 1 min, 2 min, 5 min, 10 min, 30 min and 1 h

Material

Wetted parts	stainless steel 316
Case	stainless steel

Voltage supply

Power supply	3 x 1.5 V AA alkaline batteries
Battery life	approx. 1,500 hrs. without backlighting approx. 2,000 hrs. at lower measuring rate
Battery status indication	Icon in display for low battery level

Permissible ambient conditions

Operating temperature	-10 ... +55 °C
Medium temperature	-10 ... +55 °C (lower temperature limit above the freezing point of the medium)
Storage temperature	-20 ... +70
Relative humidity	< 95 % r.H. (non-condensing)

Communication

Interface	USB, RS-232
-----------	-------------

Case

Dimensions	111 x 127 x 38 mm
Ingress protection	IP 65
Weight	approx. 455 g

4) CPGLog data-logger evaluation software is needed to use the logger function.

CE conformity, approvals and certificates

CE conformity

EMC directive	2004/108/EC, EN 61326-1 emission (group 1, class B) and interference immunity (Appendix A)
ATEX directive	II 3G Ex nA IIB T6
CSA directive	Class I, division 2, groups A, B, C, D

Approvals

GOST-R	Import certificate, Russia
GOST	Metrology/measurement technology, Russia

Certificate

Calibration	Standard: 3.1 calibration certificate per DIN EN 10204 Option: DKD/DaKKS calibration certificate
-------------	---

Approvals and certificates, see website

Available measuring ranges and resolutions

Measuring ranges and factors							
	Measuring range in bar	0 ... 0.07	0 ... 1	0 ... 2	0 ... 7	0 ... 20	0 ... 35
Unit	Conversion factor		-1 ... +1	-1 ... 2			
psi	1	1.0000	15.000	30.000	100.00	300.00	500.00
bar	0.06894757	0.0689	1.0342	2.0684	6.8948	20.684	34.474
mbar	68.94757	68.948	1,034.2	2,068.4	6,894.8	20,684	34,474
kPa	6.894757	6.8948	103.42	206.84	689.48	2,068.4	3,447.4
MPa	0.00689476	0.0069	0.1034	0.2068	0.6895	2.0684	3.4474
kg/cm ²	0.07030697	0.0703	1.0546	2.1092	7.0307	21.092	35.153
mmHg (0 °C)	51.71507	51.715	775.73	1,551.5	5,171.5	15,515	25,858
inHg (0 °C)	2.03603	2.0360	30.540	61.081	203.60	610.81	1,018.0
cmH ₂ O (4 °C)	70.3089	70.309	1,054.6	2,109.3	7,030.9	21,093	35,154
cmH ₂ O (20 °C)	70.4336	70.434	1,056.5	2,113.0	7,043.4	21,130	35,217
mmH ₂ O (4 °C)	703.089	703.09	10,546	21,093	70,309	-- 1)	-- 1)
mmH ₂ O (20 °C)	704.336	704.34	10,565	21,130	70,434	-- 1)	-- 1)
mH ₂ O (4 °C)	0.703089	0.7031	10.546	21.093	70.309	210.93	351.54
mH ₂ O (20 °C)	0.704336	0.7043	10.565	21.130	70.434	211.30	352.17
inH ₂ O (4 °C)	27.68067	27.681	415.21	830.42	2,768.1	8,304.2	13,840
inH ₂ O (20 °C)	27.72977	27.730	415.95	831.89	2,773.0	8,318.9	13,865
inH ₂ O (60 °F)	27.70759	27.708	415.61	831.23	2,770.8	8,312.3	13,854
ftH ₂ O (4 °C)	2.306726	2.3067	34.601	69.202	230.67	692.02	1,153.4
ftH ₂ O (20 °C)	2.310814	2.3108	34.662	69.324	231.08	693.24	1,155.4
ftH ₂ O (60 °F)	2.308966	2.3090	34.634	69.269	230.90	692.69	1,154.5
ft sea water	2.24719101	2.2472	33.708	67.416	224.72	674.16	1,123.6
m sea water	0.68494382	0.6849	10.274	20.548	68.494	205.48	342.47
Torr	51.71507	51.715	775.73	1,551.5	5,171.5	15,515	25,858

Measuring ranges and factors						
	Measuring range in bar	0 ... 70	0 ... 140	0 ... 200	0 ... 350	0 ... 700
Unit	Conversion factor					
psi	1	1,000.0	2,000.0	3,000.0	5,000.0	10,000
bar	0.06894757	68.948	137.90	206.84	344.74	689.48
mbar	68.94757	68,948	-- 1)	-- 1)	-- 1)	-- 1)
kPa	6.894757	6,894.8	13,790	20,684	34,474	68,948
MPa	0.00689476	6.8948	13.790	20.684	34.474	68.948
kg/cm ²	0.07030697	70.307	140.61	210.92	351.53	703.07
mmHg (0 °C)	51.71507	51,715	-- 1)	-- 1)	-- 1)	-- 1)
inHg (0 °C)	2.03603	2,036.0	4,072.1	6,108.1	10,180	20,360
cmH ₂ O (4 °C)	70.3089	70,309	-- 1)	-- 1)	-- 1)	-- 1)
cmH ₂ O (20 °C)	70.4336	70,434	-- 1)	-- 1)	-- 1)	-- 1)
mmH ₂ O (4 °C)	703.089	-- 1)	-- 1)	-- 1)	-- 1)	-- 1)
mmH ₂ O (20 °C)	704.336	-- 1)	-- 1)	-- 1)	-- 1)	-- 1)
mH ₂ O (4 °C)	0.703089	703.09	1,406.2	2,109.3	3,515.4	7,030.9
mH ₂ O (20 °C)	0.704336	704.34	1,408.7	2,113.0	3,521.7	7,043.4
inH ₂ O (4 °C)	27.68067	27,681	55,361	83,042	-- 1)	-- 1)
inH ₂ O (20 °C)	27.72977	27,730	55,460	83,189	-- 1)	-- 1)
inH ₂ O (60 °F)	27.70759	27,708	55,415	83,123	-- 1)	-- 1)
ftH ₂ O (4 °C)	2.306726	2,306.7	4,613.5	6,920.2	11,534	23,067
ftH ₂ O (20 °C)	2.310814	2,310.8	4,621.6	6,932.4	11,554	23,108
ftH ₂ O (60 °F)	2.308966	2,309.0	4,617.9	6,926.9	11,545	23,090
ft sea water	2.24719101	2,247.2	4,494.4	6,741.6	11,236	22,472
m sea water	0.68494382	684.94	1,369.9	2,054.8	3,424.7	6,849.4
Torr	51.71507	51,715	-- 1)	-- 1)	-- 1)	-- 1)

1) Due to the limited screen resolution, no values are displayed here. The resolution is limited to 100,000 digits.

Dimensions in mm

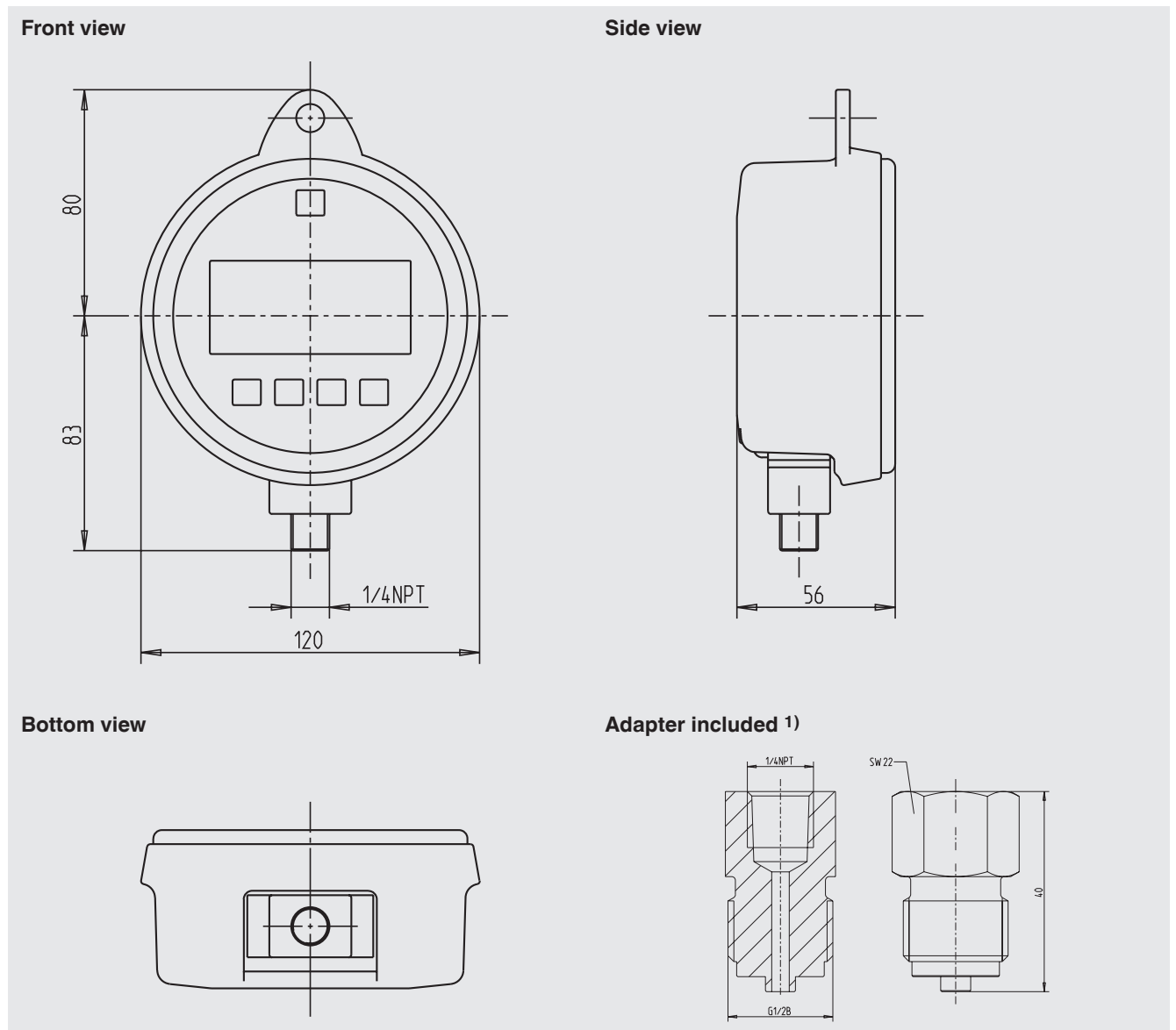

1) Not included in delivery for North America.

Front foil



- 1) Pressure display
- 2) Currently-set unit
- 3) Bargraph indicates the current pressure graphically
- 4) Selecting a configuration option
Turning the backlighting on and off
- 5) Display of the MIN/MAX values, scrolls the menu display backwards
- 6) Zero point adjustment carried out by pressing, scrolls the menu display forward
- 7) Open the configuration menu
- 8) Switches the precision digital pressure gauge on and off

Complete test and service cases



Calibration case with model CPG1000 precision digital pressure gauge and model CPP30 hand test pump, for pressures -0.95 ... +35 bar, consisting of:

- Plastic service case with foam insert
- Precision digital pressure gauge model CPG1000
- Model CPP30 pneumatic hand test pump; -0.95 ... +35 bar

Available measuring ranges see specifications

For further specifications see data sheet CT 91.06

Basic version incl. pneumatic pressure generation

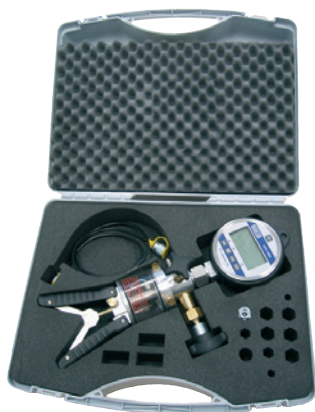

Calibration case with model CPG1000 precision digital pressure gauge and model CPP700-H hand test pump, for pressures 0 ... 700 bar, consisting of:

- Plastic service case with foam insert
- Precision digital pressure gauge model CPG1000
- Model CPP700-H hydraulic hand test pump; 0 ... 700 bar

Available measuring ranges see specifications

For further specifications see data sheet CT 91.07

Basic version incl. hydraulic pressure generation

Recommended pressure generation

Model CPP30 pneumatic hand test pump

Pressure range: -0.95 ... +35 bar

For further specifications see data sheet CT 91.06



Model CPP700-H hydraulic hand test pump

Pressure range: 0 ... 700 bar

For further specifications see data sheet CT 91.07

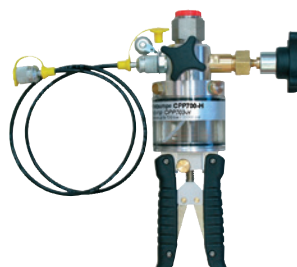

CPGLog data-logger evaluation software

Using the CPGLog data-logger evaluation software, the logger data recorded in the CPG1000 can be transferred via an interface cable to a PC and there stored in an EXCEL® file for further documentation and evaluation.

- Various logger intervals, from one second up to one hour, can be chosen.
- Data logging can range from only a few seconds up to several weeks
- Recording of the pressure value and the sensor temperature simultaneously → ideally suited to leak testing
- Four different data collection modes are possible, all data recorded or only the required points
 - Continuous (records all data within a pre-defined interval)
 - High (records only those points which lie above a previously-defined point)
 - Low (records only those points which lie below a previously-defined point)
 - Delta (records only those points which, during an interval, lie outside a predefined range)
- A maximum of 8,500 points can be recorded
- Various data points can be recorded:
 - Value at end of an interval
 - Average value
 - Minimum value
 - Maximum value
 - Median value
 - Average/Minimum/Maximum value

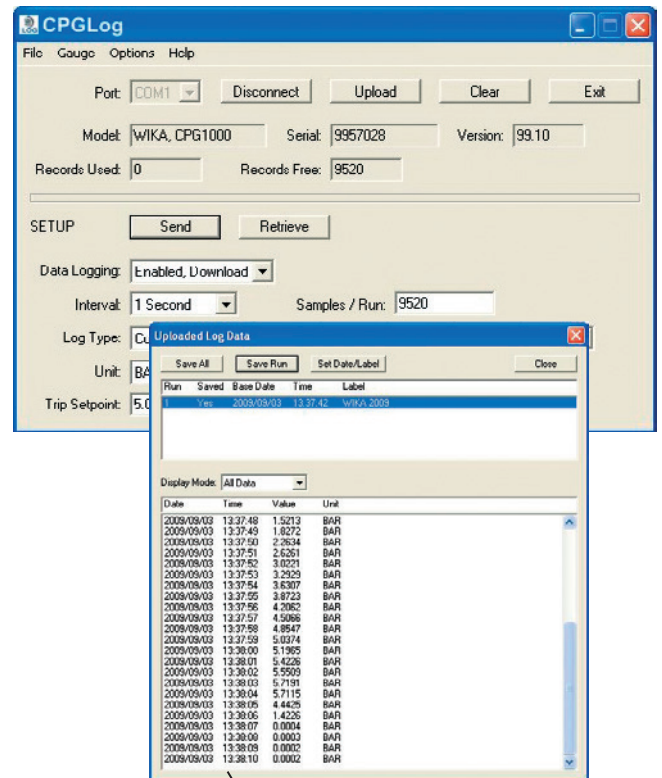

Data export e.g. to an Excel® file

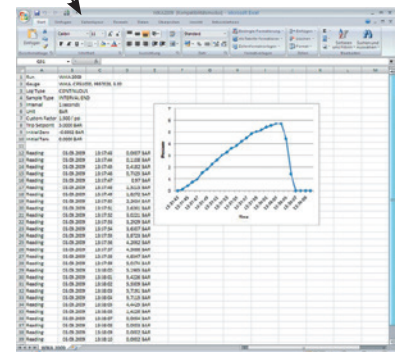

Scope of delivery (software):

- CPGLog software CD
- USB interface cable
- CPGLog operating instructions in German/English
Order No.: 11501511

WIKA-CAL calibration software

Easy and fast creation of a high-quality calibration certificate

The WIKA-CAL calibration software is used for generating calibration certificates or logger protocols for pressure measuring instruments and is available as a demo version for a cost-free download.

A template helps the user and guides him through the creation process of a document.

In order to switch from the demo version to a full version of the respective template, a USB key with the template has to be purchased.

The pre-installed demo version automatically changes to the selected full version when the USB key is inserted and is available as long as the USB key is connected to the computer.



- Creation of calibration certificates for mechanical and electronic pressure measuring instruments
- A calibration assistant guides you through the calibration
- Automatic generation of the calibration steps
- Generation of 3.1 certificates in accordance with DIN EN 10204
- Creation of logger protocols
- User-friendly interface
- Languages: German, English, Italian and more due with software updates

For further information see data sheet CT 95.10

Calibration certificates can be created with the Cal-Template and logger protocols can be created with the Log-Template.



Cal Demo

Generation of calibration certificates limited to 2 measuring points, with automatic initiation of pressures via a pressure controller.



Cal Light

Generation of calibration certificates with no limitations on measuring points, without automatic initiation of pressures via a pressure controller.



Log Demo

Creation of data logger test reports, limited to 5 measured values.



Log

Creation of data logger test reports without limiting the measured values.

Scope of delivery

- Precision digital pressure gauge model CPG1000
- Operating instructions
- 3.1 calibration certificate per DIN EN 10204
- 3 x 1.5 V AA alkaline batteries
- Adapter 1/4 NPT female to G 1/2 male ¹⁾
- Protective rubber cap for case ²⁾

1) Not included in delivery for North America.

2) Protective rubber cap not included in delivery for version with external DC 24 V voltage supply and for version with back mount process connection.

Options

- DKD/DAkKS certified accuracy
- Connection for external supply via DC 24 V ²⁾
- Back mount process connection ²⁾

Accessories

Connection adapters

- Various pressure adapters

Connection cables

- USB interface cable
- RS-232 interface cable
- USB serial adapter

Pressure generation

- Pneumatic test pumps
- Hydraulic test pumps

Test cases

- Various calibration cases incl. pressure generation

Software

- CPGLog data-logger evaluation software
- WIKA-CAL calibration software

Installation

- Mounting flange (only with back mount process connection)

Ordering information

Model / Unit / Measuring range / Process connection / Electrical connection / Test pump / Transport case / Type of certificate / Additional ordering information

© 2008 WIKA Alexander Wiegand SE & Co. KG, all rights reserved.
The specifications given in this document represent the state of engineering at the time of publishing.
We reserve the right to make modifications to the specifications and materials.

WIKA data sheet CT 10.01 · 09/2014

Page 9 of 9

