

Bimetal Thermometer, Process Grade - All Stainless Steel Construction Type TI.50, 5" Dial Size - Back Connected

Datasheet TI.50

Applications

- General process instrumentation in the chemical, petrochemical, oil and gas, energy and water/wastewater industries
- Temperature measurement in harsh and aggressive environments
- With liquid dampening suitable for applications with high vibrations

Product features

- Process grade design
- Back connection with external reset
- All stainless steel construction
- Hermetically sealed per ASME B40.3
- Accurate to 1% of full scale value
- Available with silicone case filling for vibration

Standard version

Sizes

5" (127 mm) - Type TI.50

Accuracy

+ 1.0% full scale value per ASME B40.3, Grade A

Ranges

From -100°F (70°C) to 1000°F (540°C)

From -50°C to 550°C (as single scale)

See table on page 2

Working Range

Steady: full scale value

Short time: 110% of full scale value

Over/Under Range Protection

≤ +500°F (+260°C): Temporary up to 50% of full scale

> +500°F (+260°C): Continuous to 800°F (+427°C)
Intermittant up to 1000°F (+538°C)

Connection

Material: 304 stainless steel

Center back mount (CBM), 1/2" NPT

Stem

Material: 304 stainless steel

Diameter: 1/4" (6.35 mm)

Length: 2 1/2" to 72" (63.5 mm to 1,828.8 mm)

Measuring Element

Bi-metal helix



Thermometer TI.50

Case

Material: 304 stainless steel

Hermetically sealed per ASME B40.3 standard

Weather protection NEMA 4X (IP 66)

External reset slotted hex head on back of case

Dial

White aluminum, dished, with black markings

Pointer

Black aluminum

Dampening

Inert gel to minimize pointer oscillation

Standard Scales

Single: Fahrenheit or Celsius

Dual: Fahrenheit (outer) and Celsius (inner)

Window Gasket

Neoprene

Silicone for ranges -100°F (-70°C) and

ranges > +550°F (+260°C)

Window

Flat instrument glass

Weight

16 oz. (453 g) - 5" dial

Add 1 oz. (28 g) for every 2" (50 mm) of stem length

Warranty

7- Year Warranty

Optional Extras

- Thermowells
- Silicone fill
- Dampened Movement
- Special scales and dial markings
- Acrylic and safety glass windows
- Calibration certification traceable to NIST
- Min/max pointer
- DIN standards

STANDARD RANGES		
Fahrenheit Single Scale	Dual Scale F & C F Outer, C Inner	Celsius Single Scale
-100/150 F	-100/150 F & -70/70 C	-50/50 C
-40/120 F	40/120 F & -40/50 C	-20/120 C
0/140 F	0/140 F & -20/60 C	0/50 C ¹
0/200 F	0/200 F & -15/90 C	0/100 C
0/250 F	0/250 F & -20/120 C	0/150 C
20/240 F	20/240 F & -5/115 C	0/200 C
25/125 F	25/125 F & -5/50 C	0/250 C
50/300 F	50/300 F & 10/150 C	0/300 C
50/400 F	50/400 F & 10/200 C	0/450 C ¹
50/550 F	50/500 F & 10/260 C	100/550 C ¹
150/750 F	150/750 F & 65/400 C	
200/1000 F ¹	200/1000 F & 100/540 C ¹	

¹ Not recommended for continuous service over 800°F (425°C)

Dimensions

Standard versions

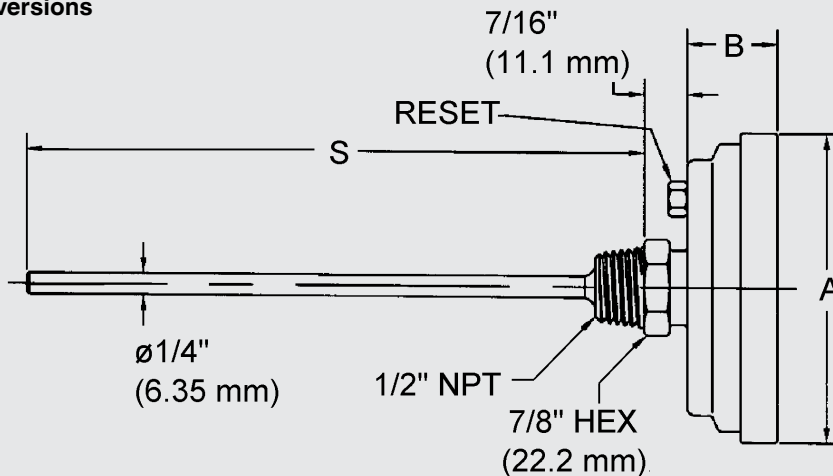

Stem Length
2½" (63.5 mm)
4" (101.6 mm)
6" (152.4 mm)
9" (228.6 mm)
12" (304.8 mm)
15" (381.0 mm)
18" (457.2 mm)
24" (609.6 mm)

WIKA Type	DIAL SIZE	A	B	S (Stem Length)
50	5" (127 mm)	5-1/4" (133.4 mm)	15/16" (23.8 mm)	As Specified

Note: Thermowells for temperature instruments are recommended for all process systems where pressure, velocity, or viscous, abrasive and corrosive materials are present individually or in combination. A properly selected thermowell protects the temperature instrument from possible damage resulting from these process variables. Furthermore, a thermowell permits removal of the temperature instrument for replacement, repair or testing without effecting the process media or the system.

Ordering information

State computer part number (if available) /type number/size/range/connection size and locations/options required. WIKA reserves the right to make changes without prior notice.



WIKA Instrument Corporation
 1000 Wiegand Boulevard
 Lawrenceville, GA 30043
 1-888-WIKA-USA /770-513-8200 (in GA)
 Fax 770-338-5118
 info@wika.com www.wika.com